



## INSTALLATION INSTRUCTIONS FOR PART 95-7521B

### APPLICATIONS

# Mazda 5 2012-up 95-7521B

### KIT FEATURES

- Double DIN head unit provision
- *Painted scratch-resistant Matte Black*

### KIT COMPONENTS

- A) Radio Housing • B) Radio Brackets

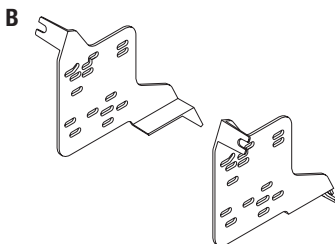
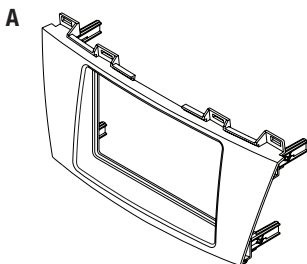

### WIRING & ANTENNA CONNECTIONS (Sold Separately)

Wiring Harness:

- 70-7903 - Mazda harness

Antenna Adapter:

- 40-HD10 - Honda antenna adapter

### TOOLS REQUIRED

Panel Removal Tool • Phillips Screwdriver • Socket Wrench

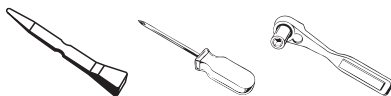

**METRA. THE WORLD'S BEST KITS.™**



**1-800-221-0932**



**metraonline.com**

© COPYRIGHT 2004-2011 METRA ELECTRONICS CORPORATION

REV. 11/8/11



95-7521B

## Table of Contents

### Dash Disassembly

– Mazda 5 2012-up..... 3-5

### Kit Assembly

– Double DIN head unit provisions ..... 6

### Caution

*Metra recommends disconnecting the negative battery terminal before beginning any installation. All accessories, switches, and especially air bag indicator lights must be plugged in before reconnecting the battery or cycling the ignition.*

*\*NOTE: Refer also to the instructions included with the aftermarket radio.*



### KNOWLEDGE IS POWER

Enhance your installation and fabrication skills by enrolling in the most recognized and respected mobile electronics school in our industry. Log onto [www.installerinstitute.com](http://www.installerinstitute.com) or call 800-354-6782 for more information and take steps toward a better tomorrow.



**Metra recommends MECP certified technicians**

## Dash Disassembly

1. Unclip and remove the cup holder panel in the center console. (Figure A)
2. Unclip and remove the small pocket panel on the back of the center console behind shifter. (Figure B)
3. Remove (2) 8mm bolts under cup holder panel holding the back half of the center console to the front half. (Figure C)
4. Unscrew and remove the shift knob. (Figure D)

*Continued on next page*

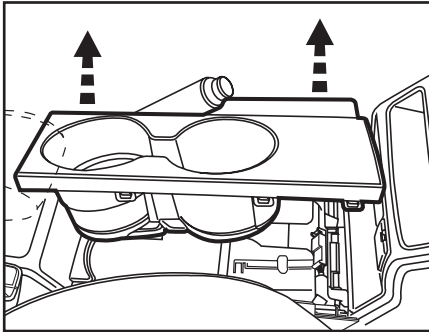

(Figure A)

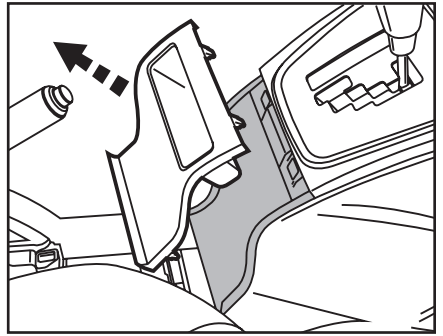

(Figure B)

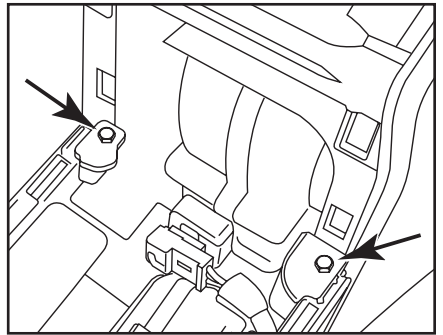

(Figure C)

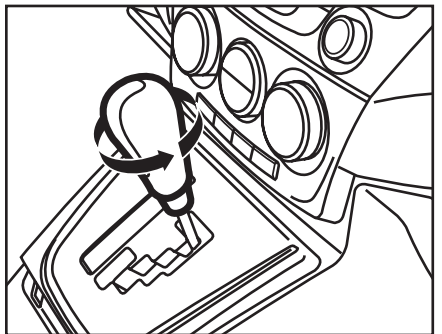

(Figure D)

## Dash Disassembly

5. Unclip and remove the shifter trim panel. (Figure D)
6. Slide both seats forward and remove (2) Phillips screws on each side of the center console under the screw covers. (Figure E)
7. Unclip and pull back the panels at the lower front sides of the center console. (Figure F)
8. Remove (2) Phillips screws from both sides (total of 4) of the front lower half of the center console. (Figure G)

*Continued on next page*

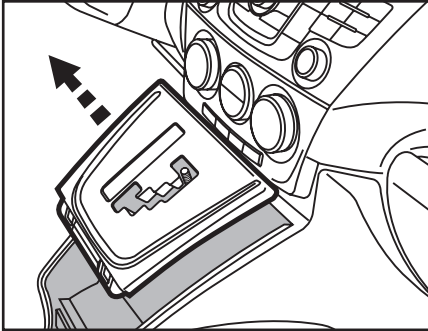

(Figure D)

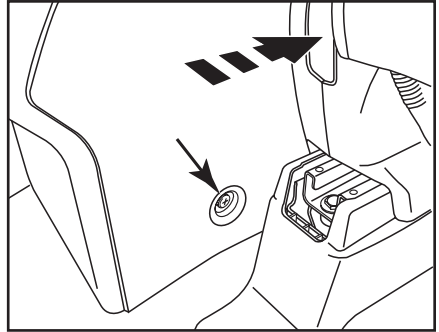

(Figure E)

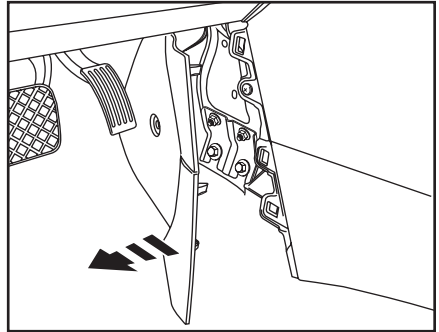

(Figure F)

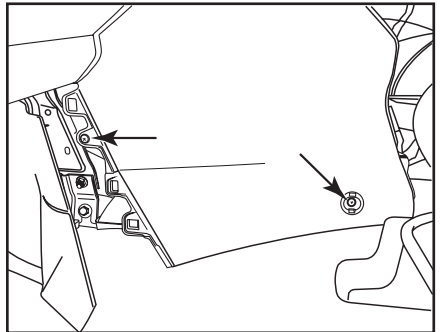

(Figure G)

## Dash Disassembly

9. Unclip and remove the vent panel including the hazard switch above the factory radio. (Figure H)
10. Unclip the entire center console and slide it towards the rear of the vehicle to gain access to the (2) Phillips screws on the bottom of the a/c control. (Figure I)
11. Remove the (2) Phillips screws from the a/c control then unclip and remove the control. (Figure J)
12. Remove (3) Phillips screws and (1) 10 mm bolt securing the radio. (Figure K)

*Continue to kit assembly*

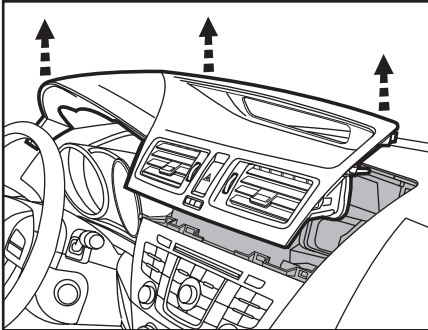

(Figure H)

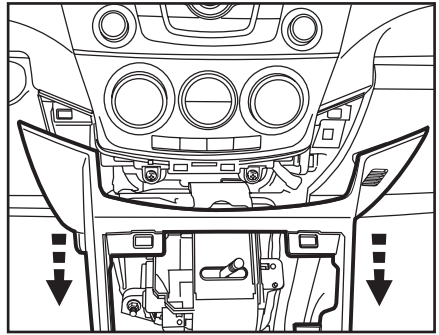

(Figure I)

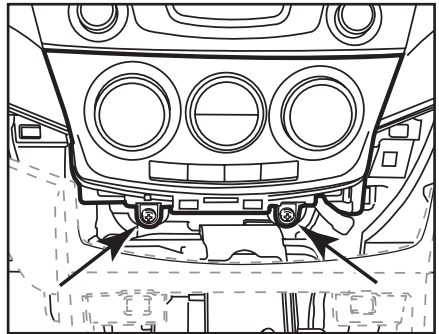

(Figure J)

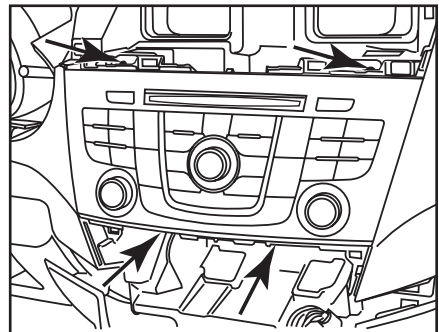

(Figure K)



## Kit Assembly 95-7521B

### Double DIN head unit provisions

1. Mount the radio to the radio brackets with the screws supplied with the unit. (Figure A)
2. Locate the factory wiring harness in the dash. Metra recommends using the proper mating adapter from Metra or AXCESS. Test the unit for proper operation.
3. Mount the radio/bracket assembly into the dash. (Figure B)
4. Install the radio trim panel over the radio/bracket assembly and reassemble dash in reverse order of disassembly.

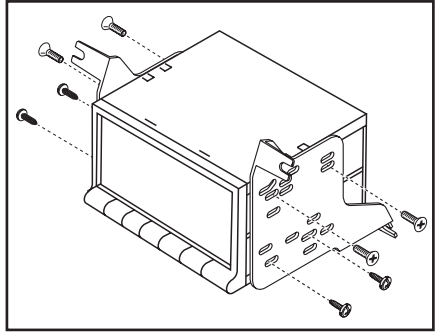

(Figure A)

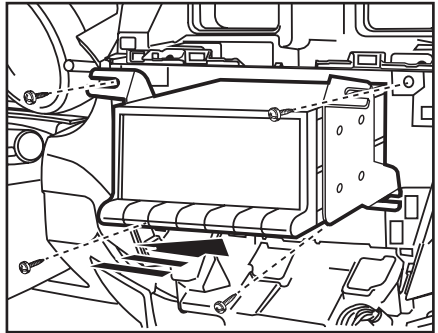

(Figure B)





**INSTALLATION INSTRUCTIONS FOR PART 95-7521B**

REV. 11/8/11

**METRA. THE WORLD'S BEST KITS.™**



**1-800-221-0932**



**metraonline.com**

© COPYRIGHT 2004-2011 METRA ELECTRONICS CORPORATION





## INSTRUCCIONES DE INSTALACIÓN PARA LA PIEZA 95-7521B

### APLICACIONES

# Mazda 5 2012 y mas 95-7521B

### CARACTERÍSTICAS DEL KIT

- Provisiones de unidad central Double DIN:
- *Pintado negro mate resistente a rayaduras*

### COMPONENTES DEL KIT

- A) Alojamiento de radio • B) Soportes de radio

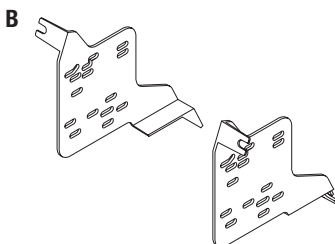
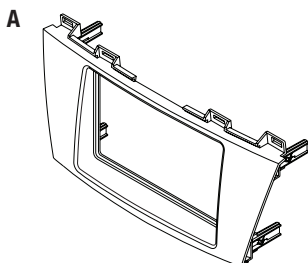

### CABLEADO Y CONEXIONES DE ANTENA (Se venden por separado)

Arnés de cableado:

- Arnés Mazda 70-7903

Adaptador de antena:

- Adaptador de antena Honda 40-HD10

### HERRAMIENTAS REQUERIDAS

Herramienta de remoción de panel • Destornillador Phillips • Llave para dados

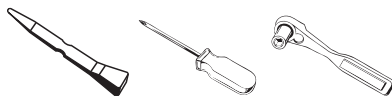

**METRA. THE WORLD'S BEST KITS.™**



**1-800-221-0932**



**metraonline.com**

© COPYRIGHT 2004-2011 METRA ELECTRONICS CORPORATION

REV. 11/8/11



95-7521B

## Indice

### Desmontaje del tablero

– Mazda 5 2012 y mas ..... 3-5

### Ensamble del kit

– Provisiones de unidad central Double DIN: ..... 6

### Precaución

***Metra recomienda desconectar la terminal negativa de la batería antes de iniciar cualquier instalación. Todos los accesorios, interruptores y especialmente las luces del indicador de las bolsas de aire deben estar conectados antes de reconectar la batería o ciclar la ignición.***

***\*NOTA: Asimismo, remítase a las instrucciones incluidas con el radio de posventa.***



#### KNOWLEDGE IS POWER

Enhance your installation and fabrication skills by enrolling in the most recognized and respected mobile electronics school in our industry. Log onto [www.installerinstitute.com](http://www.installerinstitute.com) or call 800-354-6782 for more information and take steps toward a better tomorrow.



**Metra recommends MECP certified technicians**

## Desmontaje del tablero

1. Desprenda y retire el panel del portavasos de la consola central. (Figure A)
2. Desprenda y retire el pequeño panel de bolsillo de la parte posterior de la consola central que está detrás de la palanca de velocidades. (Figure B)
3. Retire los pernos de 8 mm (2) que están debajo del panel del portavasos uniendo la parte trasera de la consola central con la parte frontal. (Figure C)
4. Desatornille y retire la perilla de la palanca de velocidades. (Figure D)

*Continuado en la paginación siguiente*

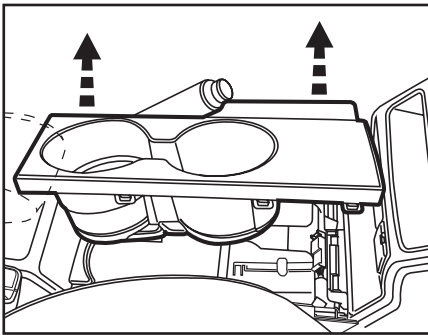

(Figure A)

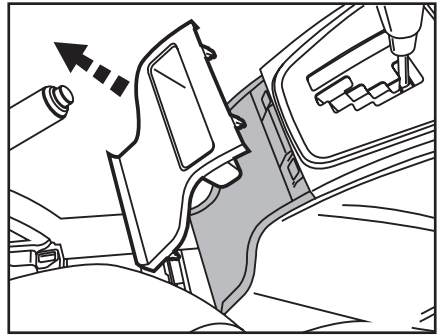

(Figure B)

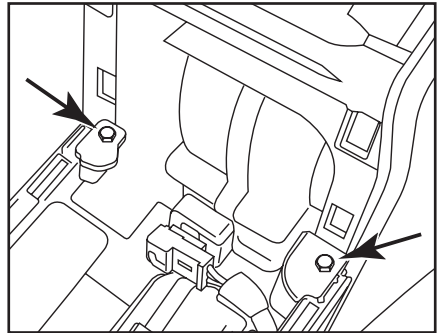

(Figure C)

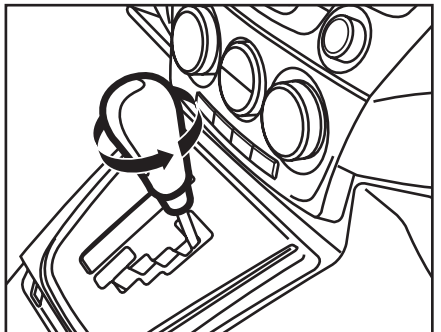

(Figure D)

## Desmontaje del tablero

5. Desprenda y retire el panel decorativo de la palanca de velocidades (Figure D)
6. Deslice ambos asientos hacia adelante y retire los tornillos Phillips (2) de cada lado de la consola central bajo los tapones de los tornillos. (Figure E)
7. Desprenda y jale hacia atrás los paneles de los lados frontales inferiores de la consola central. (Figure F)
8. Retire los tornillos Phillips (2) de ambos lados (4 en total) de la mitad frontal inferior de la consola central. (Figure G)

*Continuado en la paginación siguiente*

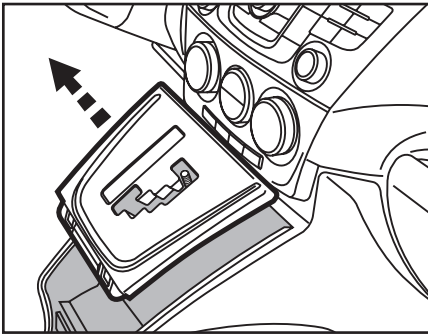

(Figure D)

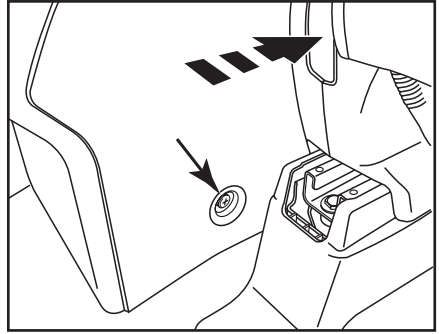

(Figure E)

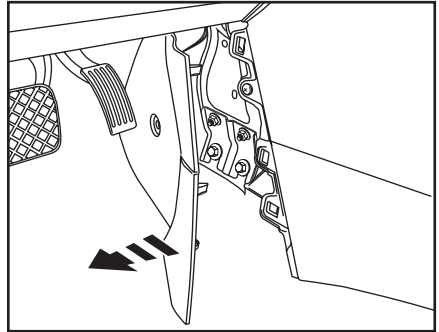

(Figure F)

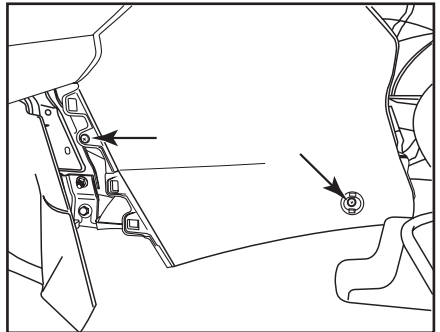

(Figure G)

## Desmontaje del tablero

9. Desprenda y retire el panel de ventilación, incluyendo el interruptor de las luces intermitentes que está sobre el radio de fábrica. (Figure H)
10. Desprenda toda la consola central y deslícela hacia la parte trasera del vehículo para obtener acceso a los tornillos Phillips (2) en la parte inferior del control de a/c. (Figure I)
11. Retire los tornillos Phillips (2) del control de a/c, después desprenda y retire el control. (Figure J)
12. Retire los tornillos Phillips (3) y un (1) perno de 10 mm que aseguran el radio. (Figure K)

*Continúe al ensamble del kit*

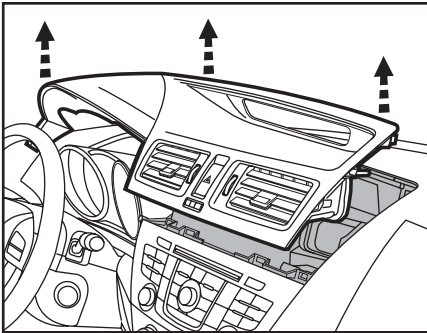

(Figure H)

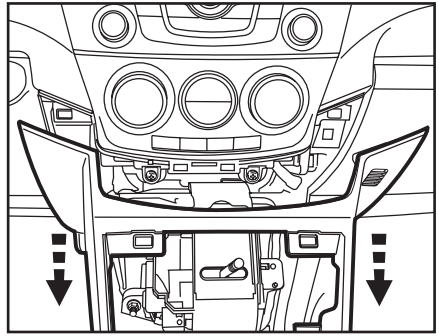

(Figure I)

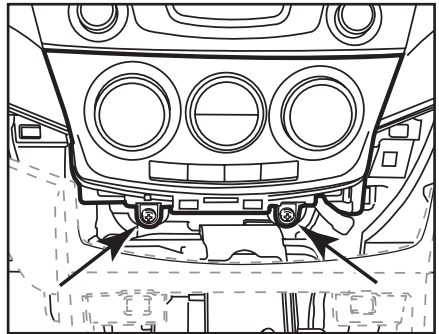

(Figure J)

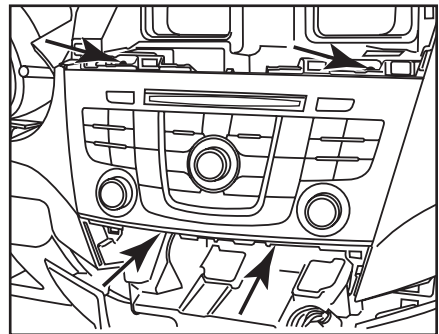

(Figure K)



## Ensamble del kit 95-7521B

### Provisiones de unidad central Double DIN:

1. Monte el radio en los soportes del radio con los tornillos suministrados con la unidad. (Figure A)
2. Ubique el arnés de cableado de fábrica en el tablero. Metra recomienda el uso de adaptadores adecuados de acoplamiento de Metra y/o AXXESS. Pruebe si la unidad funciona adecuadamente.
3. Monte el ensamble de radio/soporte en el tablero. (Figure B)
4. Instale la placa decorativa del radio sobre el ensamble del radio/soporte y vuelva a armar el tablero en orden inverso al desmontaje.

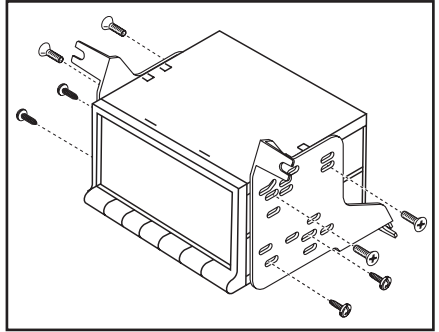

(Figure A)

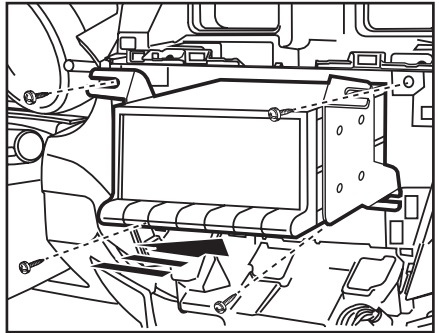

(Figure B)





## INSTRUCCIONES DE INSTALACIÓN PARA LA PIEZA 95-7521B

REV. 11/8/11

**METRA. THE WORLD'S BEST KITS.™**



**1-800-221-0932**



**metraonline.com**

© COPYRIGHT 2004-2011 METRA ELECTRONICS CORPORATION