



## Toyota Sienna (without NAV) Toyota Sienna (with upper model 7-inch NAV) 2011-2014

### KIT FEATURES

- ISO DIN radio provision with pocket
- ISO DDIN radio provision
- Painted silver to match factory dash

### KIT COMPONENTS

- A) Radio housing • B) Radio brackets • C) Pocket • D) (8) #8 x 3/8" Phillips screws

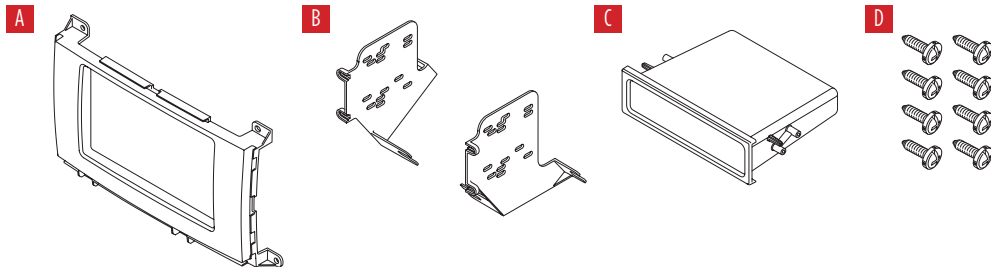

### TABLE OF CONTENTS

Dash Disassembly.....	2
Kit Assembly	
–ISO DIN radio provision with pocket.....	3
–ISO DDIN radio provision.....	4

### WIRING & ANTENNA CONNECTIONS (sold separately)

Wiring Harness: •70-1761 • TYTO-01

Antenna Adapter: Not required

Steering wheel control interface: ASWC-1

### TOOLS REQUIRED

- Phillips screwdriver • Socket wrench
- Panel removal tool/flat blade screwdriver

**CAUTION!** All accessories, switches, climate controls panels, and especially air bag indicator lights must be connected before cycling the ignition. Also, do not remove the factory radio with the key in the on position, or while the vehicle is running.

## DASH DISASSEMBLY

1. Unclip and remove the trim panel above the glove box and below the A/C control. (Figure A)
2. Pull down on the collar below the shifter knob and untwist the shifter knob to remove it. (Figure B)
3. Unclip and remove the shifter trim panel. (Figure B)
4. Unclip and remove the A/C control. (Figure C)
5. Remove (4) 10mm bolts securing the radio. (Figure D)
6. Remove the (4) Phillips screws securing the outer A/C vent trim panel to the factory radio and separate. (Figure E)

*Continued on Kit Assembly*

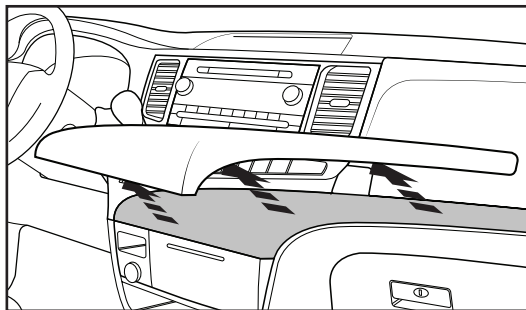

(Figure A)

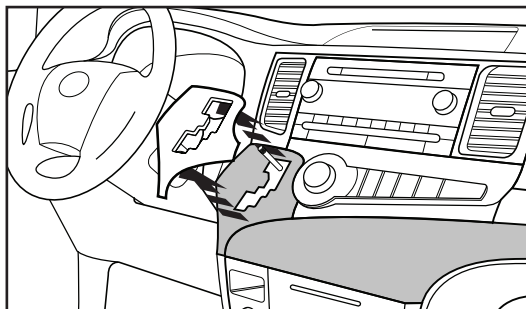

(Figure B)

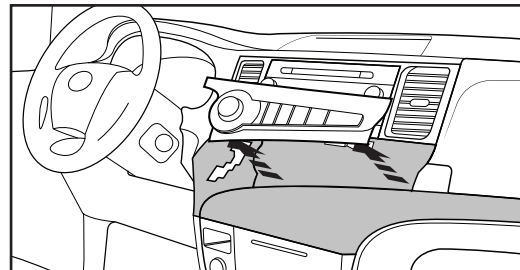

(Figure C)

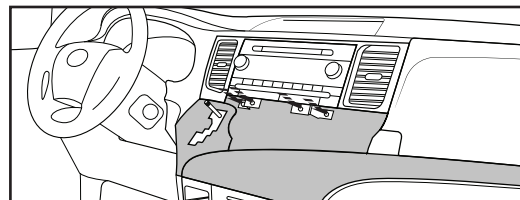

(Figure D)

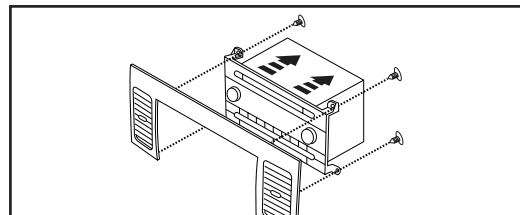

(Figure E)

## KIT ASSEMBLY

### ISO DIN radio provision with pocket

1. Secure the *radio brackets* to the *radio housing* with (4) #8 3/8" Phillips screws provided. (Figure A)
2. Attach the *pocket* to the bracket/radio housing assembly with the (4) #8 3/8" Phillips screws provided. (Figure B)
3. Remove the metal DIN sleeve and trim ring from the aftermarket radio.
4. Align the holes in the *radio brackets* with the holes in the radio and secure the brackets to the radio with the screws included with the radio. (Figure C)
5. Attach the outer a/c vent trim panel to the *radio housing* using the factory hardware. (Figure D)
6. Locate the factory wiring harness in the dash. Metra recommends using the proper mating adapter from Metra or AXXESS. Test the radio for proper operation.
7. Reassemble the dash in reverse order of disassembly.

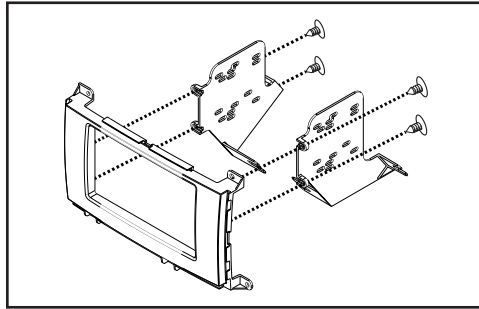

(Figure A)

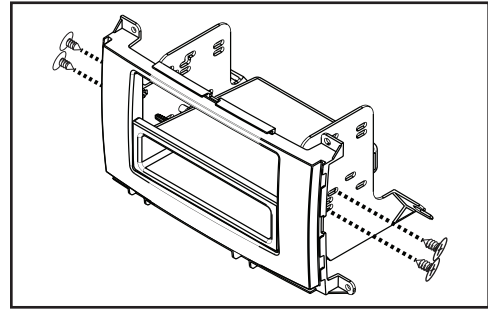

(Figure B)

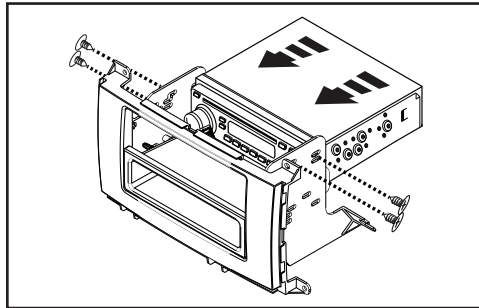

(Figure C)

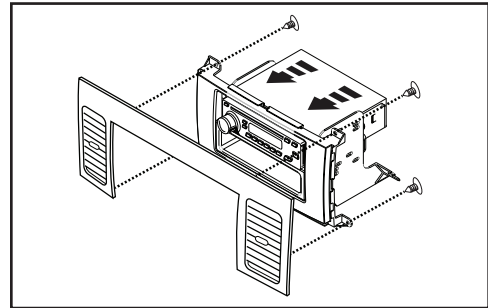

(Figure D)



### KIT ASSEMBLY

#### ISO DDIN radio provision

1. Secure the *radio brackets* to the *radio housing* with (4) #8 x 3/8" Phillips screws provided. (Figure A)
2. Slide the radio into the bracket/radio housing assembly and secure to the assembly using the screws supplied with the radio. (Figure B)
3. Attach the outer A/C vent trim panel to the *radio housing* using the factory hardware. (Figure C)
4. Locate the factory wiring harness in the dash. Metra recommends using the proper mating adapter from Metra or AXXESS. Test the radio for proper operation.
5. Reassemble the dash in reverse order of disassembly.

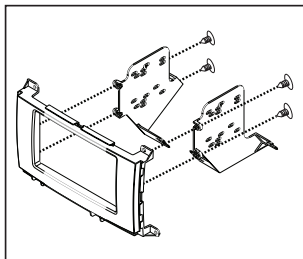

(Figure A)

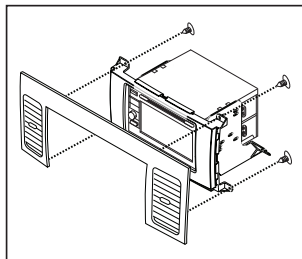

(Figure C)

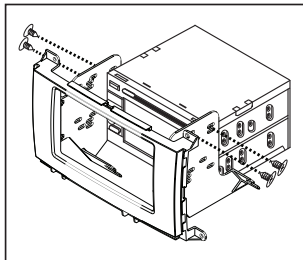

(Figure B)

#### IMPORTANT

*If you are having difficulties with the installation of this product, please call our Tech Support line at 1-800-253-TECH. Before doing so, look over the instructions a second time, and make sure the installation was performed exactly as the instructions are stated. Please have the vehicle apart and ready to perform troubleshooting steps before calling.*



#### KNOWLEDGE IS POWER

Enhance your installation and fabrication skills by enrolling in the most recognized and respected mobile electronics school in our industry. Log onto [www.installerinstitute.com](http://www.installerinstitute.com) or call 800-354-6782 for more information and take steps toward a better tomorrow.



**Metra recommends MECP certified technicians**